

DR-S210 HIGH PRECISION DIGITAL PRESSURE GAUGE



TECHNICAL CHARACTERISTICS:

- ✓ 105mm diameter, 304 SS shell
- ✓ 5digits display, main & sub- screen dual screen design
- ✓ 10 units are available: MPa/kPa/psi/BAR/Pa/mBAR/mmHg/mH2O/Torr/Kgf/cm ■
- ✓ low power design,3 AA batteries and can lasts up to 3600 hours
- ✓ Product certificate: CE, Explosion Certificate Exib IICT4

This high-precision digital pressure gauge adopts a 55x55mm large-size LCD screen. It uses a crossover display of the main screen and the sub-screen. It can display the real-time pressure and simultaneously display the reference data such as the on-site temperature and pressure maximum/minimum. The product is powerful, preset 10 pressure units, adjustable pressure sampling rate, battery power display, the product is equipped with USB external power supply and battery dual power supply mode. This product is powered by three 5th batteries and features an ultra-low power design for up to 3,600 hours of battery life. The product adopts high-precision ADC and high-speed microprocessor, full digital design, high precision and good stability. The product is made of 304 stainless steel material, equipped with carrying case and power supply accessory, which is beautiful and practical.

APPLICATION:

- ◇ Mechanical electronics industry ◇ Supporting equipment of instrument
- ◇ Pressure Laboratory ◇ Construction mech automation
- ◇ Replace the pointer precision pressure gauge and can be used as a standard pressure gauge for verifying pressure transmitters & ordinary pressure gauges

SPECIFICATION:

Range	Micropressure: (1...2.5...25) kPa Low Pressure: (40...60...250) kPa Medium Voltage: (0.4...0.6...4) MPa High Pressure: (6...10...25) MPa Ultra High Pressure: (40...60...160) MPa Compound Range: (-2.5~2.5...5...-100~1000) kPa Absolute Pressure: (0~10...25...1000) kPa Differential Pressure: (0~10...25...40...60...100...250...400...600)kPa (0~1...1.6)MPa
Overload Capacity	150%(> 10MPa) ;200%(≤10MPa)
Backlight Color	White
Dial Size	105mm
Acc.	0.05%FS 0.1%FS
Output Signal	RS 485
Long-term Stability	Typical: ± 0.1%FS/year
Operation Temperature	-5~40°C
Compensation Temperature	0~40°C
Electric Protection	Anti Electro Magnetic Interference
Sampling Frequency	1-10 times/second
Measurement Medium	Gas or liquid compatible with 316 stainless steel
Pressure Connection	M20*1.5 G1/4 NPT1/4(customized)
Connection Material	304SS
Shell Material	304SS
Function	Power On/Off Backlight Clear Unit Switch Extreme Value Display
Power Supply	3 AA batteries/USB supply
Accessory	Carrying case / USB power cord
Product Certificate	CE Explosion Certificate(Exib IICT4)
IP rating	IP50 (IP54with protection sleeve)

SIZE:

UNIT:mm

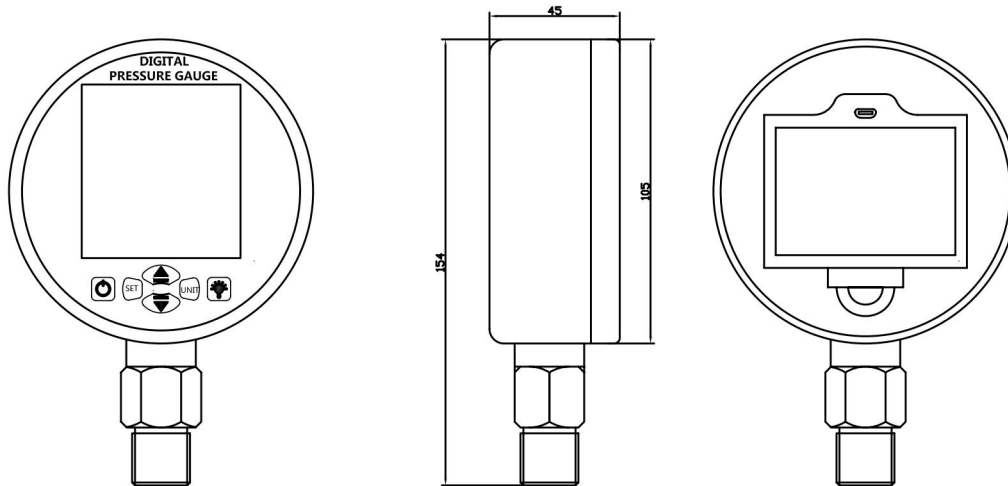

SELECTION GUIDE:

DR-S210 E - P - 1M-3 - P2-R-M20-T0-L

Model:
S210(105mm)

Installation mode :
E(Radial Installation)
Z(Axial Installation)

Feature:
X(Normal)
P(Homogeneous Membrane)
DP(Differential Pressure)
KF(Clamp) DN(Flange)

Range:
X k (0-X kPa)
X b(0-X bar)
X M(0-XMPa)

Accuracy:
3 (0.1%) 5(0.05%)

Addition:

L(Display)
I(Explosion-proof)

Medium temperature:

T0 (-5~40°C)
T9 (Customized)

Connection:

M20(M20*1.5) G14(G1/4)
G12(G1/2) N12(NPT1/2)
N14(NPT1/4) ZG14(ZG1/4)
M9(Customized)

Output signal :
R(RS485)

Power supply :
P0(3V) P2(24V)